

## **IOT-BASED AUTOMATIC WATERING SYSTEM FOR TOMATO PLANTS WITH SOIL MONITORING**

**Devanda Yudha Bharagus<sup>1</sup>, I Kadek Dwi Nuryana<sup>2</sup>**

*<sup>1,2</sup>Surabaya State University, Surabaya, Indonesia*

*[Devandayudha.20085@mhs.unesa.ac.id](mailto:Devandayudha.20085@mhs.unesa.ac.id), [dwinuryana@unesa.ac.id](mailto:dwinuryana@unesa.ac.id)*

### **ABSTRACT**

The development of the Internet of Things (IoT) technology has significantly contributed to plant maintenance, particularly in automated irrigation systems. Tomato plants require optimal soil conditions, especially soil moisture and soil pH, to grow properly. The ideal soil pH for tomato plants ranges from 6.0 to 6.8, while soil moisture levels should be maintained between 60% and 80%. However, manual tomato plant care often encounters problems due to a lack of understanding of plant requirements and improper irrigation timing. This study aims to design and develop an automatic tomato irrigation system based on the Internet of Things (IoT) with real-time monitoring of soil moisture and soil pH through a web-based interface. The system uses an ESP32 microcontroller as the main controller, along with a soil moisture sensor and a soil pH sensor. Sensor data are processed to automatically control the water pump based on a predetermined soil moisture threshold. System testing was conducted ten times under various soil conditions. The results show that when the soil moisture value exceeds 80%, the water pump automatically turns off, whereas when the value falls below 80%, the pump turns on to perform irrigation. These results indicate that the system operates according to the defined threshold and is able to maintain optimal soil moisture conditions. The implementation of this system improves the efficiency, effectiveness, and control of tomato plant maintenance.

**Keywords:** Internet of Things, ESP32, Automatic Irrigation, Soil Moisture Sensor, Soil pH Sensor, Tomato Plants, Web Monitoring.

#### **Article Info:**

*Article history:*

*Received February 23, 2026*

*Revised March 05, 2026*

*Accepted May 25, 2026*

#### **Corresponding Author**

Devanda Yudha Bharagus

Surabaya State University, Surabaya, Indonesia

[Devandayudha.20085@mhs.unesa.ac.id](mailto:Devandayudha.20085@mhs.unesa.ac.id)

### **1. INTRODUCTION**

The development of Internet of Things (IoT) technology enables devices to be interconnected through the internet network to perform real-time monitoring and control [1]. The utilization of IoT in agriculture has been widely implemented to improve plant maintenance efficiency [2].

Tomato plants require soil conditions with appropriate moisture and pH levels to achieve optimal growth. Imbalance in water content can hinder plant development, while unsuitable soil pH can disrupt nutrient absorption [3].

Several previous studies have developed IoT-based automatic irrigation systems using soil moisture sensors and monitoring through web platforms or instant messaging applications [4]. In addition, IoT-based soil pH monitoring systems have also been implemented to improve plant productivity [5].

Based on previous studies, a system is needed that integrates real-time website-based soil moisture and pH monitoring and provides historical data recording. Therefore, this research develops an IoT-based automatic watering system with monitoring through a website.

## 2. METHODS

The method used is the Prototype method, which consists of stages of requirement identification, system design, prototype development, and system testing. The prototype method is widely used in IoT system development because it allows gradual evaluation and improvement [6].

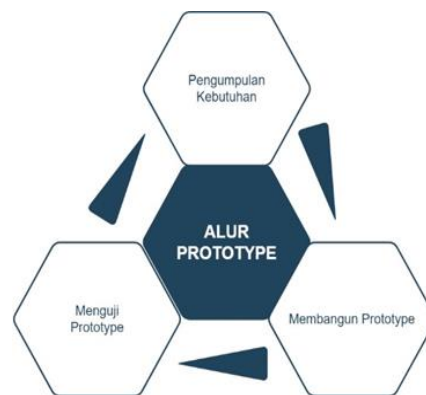

Figure 1. Prototype Flow

### A. Requirement Collection

Determining hardware and software requirements such as ESP32, which was chosen because it has an integrated WiFi module that supports IoT data communication [7], the soil moisture sensor works based on soil resistance to water [8], the pH sensor is used to measure soil acidity level analogously [9], relay, water pump, and a website-based monitoring system that allows flexible and real-time data access through the internet network [10].

### B. Building the Prototype

The automatic watering process scheme is controlled through a Website interface using a simple design concept, which includes input, process, and output. The system is designed using the Input–Process–Output concept. The Input includes the Soil Moisture Sensor, Soil pH Sensor, and Website. In the Process section, ESP32 processes sensor data and compares it with the moisture threshold of 80%. Finally, in the Output section, the Relay activates or deactivates the water pump, data is sent to the server, and the Website displays the monitoring results.

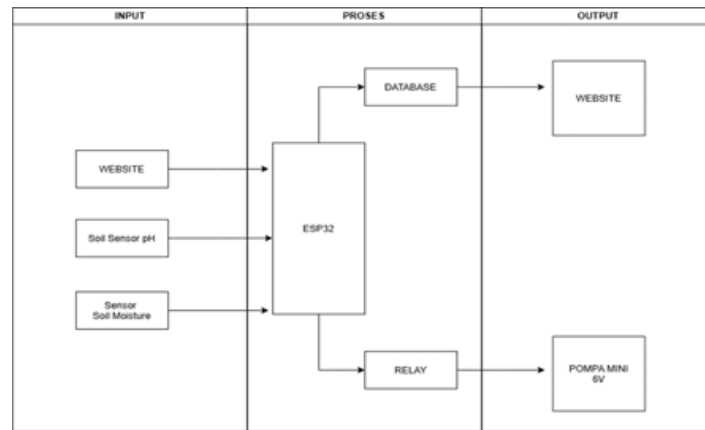

Figure 2. Design Concept

### C. Prototype Testing

The testing process is carried out after the device is designed. The next stage is testing all components to check whether they function properly. At the testing stage, real objects are used to prevent system damage due to potential errors. If the system passes the first object test, the final process is tested directly on the research object.

## 3. RESULTS AND DISCUSSION

### 3.1 Website Development

#### A. Dashboard Page Before the System Operates

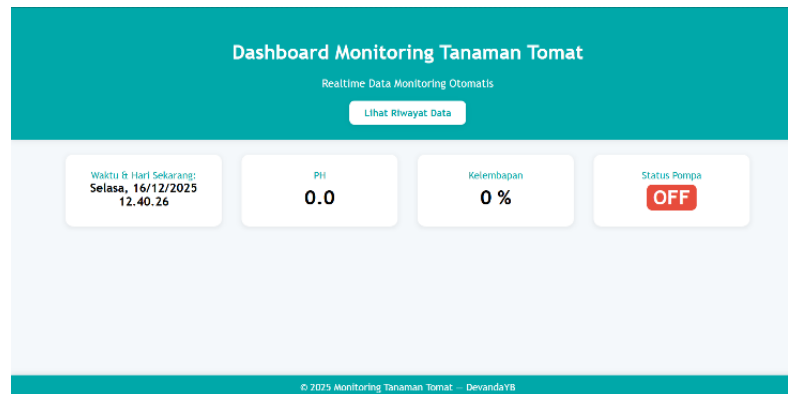

Figure 3. Dashboard page before the system operates

On the dashboard page, before the automatic watering system operates, the soil moisture value read by the sensor is 0% with a soil pH value of 0.0. In this condition, the system has not performed the watering process, so the water pump is inactive (OFF).

#### B. Dashboard Page When the Soil is Dry

After the system is activated, ESP32 reads soil moisture sensor data under dry soil conditions. When the moisture value is below the threshold, which is 39%, the water pump is activated through the relay until the moisture reaches more than 80%. Then the pump turns on automatically, while the soil pH value is around 13.43.

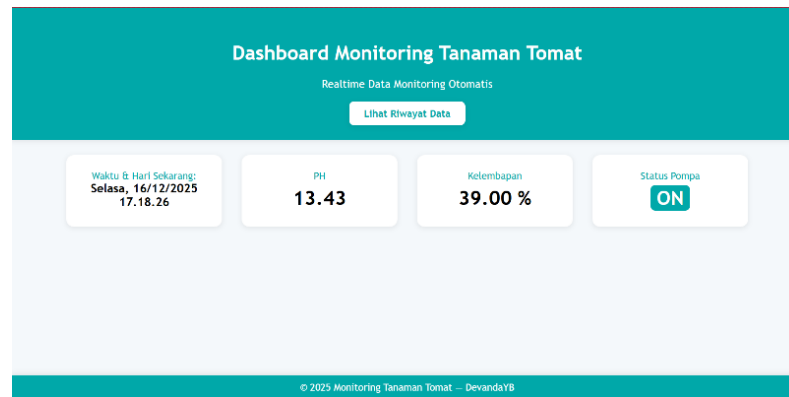

Figure 4. Dashboard page when the soil is dry

C. Dashboard Page When the Soil is Wet

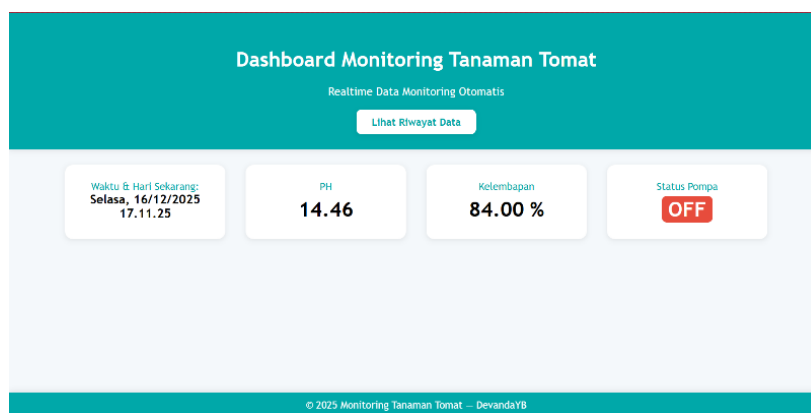

Figure 5. Dashboard page when the soil is wet

After ESP32 reads the soil moisture sensor data, when the moisture value is below the threshold, the water pump is activated through the relay until the moisture reaches more than 84%. Then the pump turns off automatically, showing that soil moisture increases from 39% to 84%, while the soil pH value is around 14.46.

D. History Page

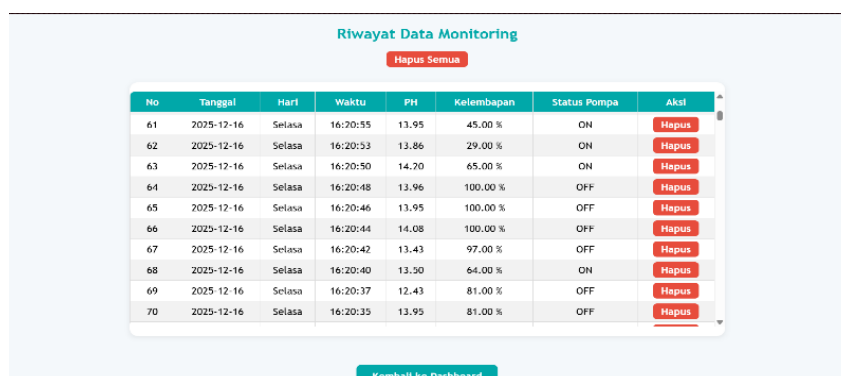

Figure 6. History Page

The watering history page displays historical data of soil conditions after the automatic watering system operates. This page functions to record changes in soil conditions after the watering process is automatically carried out by the system.

### 3.2 IoT Circuit

In the hardware development stage of the IoT system, the soil moisture sensor is used to measure soil moisture in percentage form (%). The system uses ESP32 as the controller, a pH sensor to measure soil acidity, a relay as an automatic switch, and a 5V mini pump for watering. ESP32 processes sensor data and automatically activates the pump when soil moisture is below the determined limit.

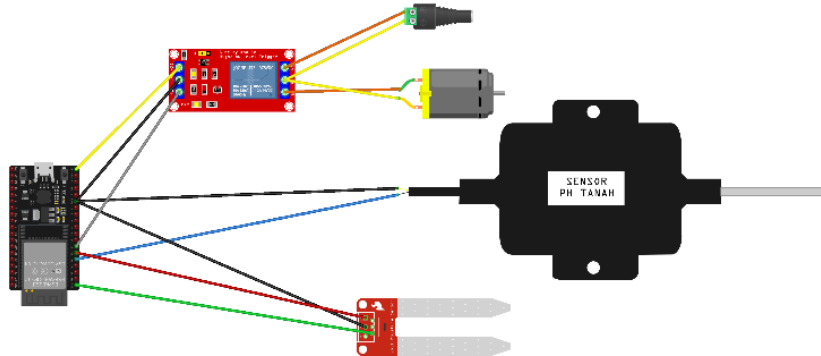

Figure 7. IoT Circuit

Table 1. Pin circuit on ESP32 and Soilmoisture Sensor

ESP32	Sensor Soilmoisture	Function
Pin 35	AO	Receives control signals from the microcontroller to obtain values from the sensor
GND	GND	Provides ground power between the ESP32 and the sensor for smooth communication
3.3 V	VCC	Provides power for the sensor to function

Table 2. Pin circuit on ESP32 and Soil Ph Sensor

ESP32	Sensor PH tanah	Function
Pin 34	+	Obtaining the pH value from the soil pH sensor
GND	-	Provides a ground current between the ESP32 and the sensor for smooth communication

Table 3. Pin circuit on ESP32 and Relay

ESP32	Relay	Function
Pin 32	IN	Receives control signals from the microcontroller to activate the relay function
GND	-	Provides ground power between the ESP32 and the relay for smooth communication
Pin 5V	+	Provides power so that the relay module can function

Table 4. Pin circuit on the Relay and Pump

Relay	Pompa	Function
NO	+	To set the water pump off and on
COM	-	Provides a ground current between the relay and ensures that communication can run smoothly

### 3.3 Sensor Testing

#### A. Soil Moisture Sensor Testing

Table 5. Soil Moisture Sensor Testing

No	Soil Condition	Humidity (%)	Description
1	Dry	60%	Very dry soil
2	Slightly moist	75%	Below threshold
3	Normal	80%	Pump OFF
4	Moist	100%	Wet soil

In the hardware development of the IoT system, the soil moisture sensor produces soil moisture values in percentage form (%). The system consists of ESP32 as the controller, soil moisture sensor, soil pH sensor, relay, and 5V mini pump. Testing under various soil conditions shows that moisture values increase as water content increases. The results are displayed on the monitoring dashboard and prove that the sensor is capable of detecting soil changes as the basis for automatic watering.

## B. Soil pH Sensor Testing

Table 6. Soil pH Sensor Testing

No	Media Tanah	Nilai pH	Description
1	Wet Soil	7.6	Moist
2	Dry Soil	20.89	Dry

The test results show that the pH sensor can provide stable readings according to soil characteristics, so the pH sensor can be used as a monitoring parameter without affecting the watering process.

## C. Water Pump Testing

Table 7. Water Pump Testing

No	Humidity (%)	Expected Pump Status	Pump Status	Description
1	35%	ON	ON	Success
2	79%	ON	ON	Success
3	80%	OFF	OFF	Success
4	100%	OFF	OFF	Success

Testing was conducted by providing different soil moisture conditions. When the soil moisture value is below the predetermined threshold, the system automatically activates the water pump. Conversely, when the soil moisture value reaches the specified level, the pump stops automatically.

## D. Testing Before and After Watering

Table 8. Testing Before and After Watering

No	Parameter	Before	After
1	Soil Moisture	30%	80%
2	Soil pH	20.89	6.5
3	Pump Status	ON	ON selama 10 detik lalu OFF
4	Soil Condition	Dry	Moist

Testing before and after watering was conducted to evaluate the effectiveness of the automatic system. Under dry soil conditions, the sensor reads a value below the threshold, so the pump is automatically activated. After watering, soil moisture increases to reach the specified limit, and the pump stops. The comparison results show that the system effectively increases soil moisture while maintaining stable pH values.

## E. Sensor Data Reading Results

no	tanggal	hari	waktu	PH	kelembapan	pompa
1	16/12/2025	Selasa	14:57:38	20.89	30%	ON
2	16/12/2025	Selasa	14:57:40	3.78	41%	ON
3	16/12/2025	Selasa	14:57:42	20.89	39%	ON
4	16/12/2025	Selasa	14:57:44	20.89	36%	ON
5	16/12/2025	Selasa	14:57:47	20.89	29%	ON
6	16/12/2025	Selasa	14:57:49	12.31	61%	ON
7	16/12/2025	Selasa	14:57:51	20.89	67%	ON
8	16/12/2025	Selasa	14:57:53	19.15	68%	ON
9	16/12/2025	Selasa	15:00:19	20.89	79%	ON
10	16/12/2025	Selasa	15:00:22	20.89	82%	OFF
11	16/12/2025	Selasa	15:01:43	14.25	85%	OFF
12	16/12/2025	Selasa	15:08:21	13.46	86%	OFF
13	16/12/2025	Selasa	15:08:24	10.25	85%	OFF
14	16/12/2025	Selasa	15:08:26	12.44	80%	OFF
15	16/12/2025	Selasa	15:08:28	15.02	81%	OFF
16	16/12/2025	Selasa	15:08:31	12.12	84%	OFF
17	16/12/2025	Selasa	15:08:33	9.65	86%	OFF
18	16/12/2025	Selasa	15:08:35	9.70	95%	OFF
19	16/12/2025	Selasa	15:08:37	10.50	75%	ON
20	16/12/2025	Selasa	15:08:40	10.11	69%	ON
21	16/12/2025	Selasa	15:08:42	10.30	78%	ON
22	16/12/2025	Selasa	15:08:45	11.80	85%	OFF
23	16/12/2025	Selasa	15:08:47	9.10	95%	OFF
24	16/12/2025	Selasa	15:30:09	7.50	90%	OFF
25	16/12/2025	Selasa	15:30:11	11.47	86%	OFF

Figure 8. Data value results

Based on the test results, the ESP32-based automatic watering system operates according to the design. The system is able to read soil moisture in real-time and activate the pump when the soil is dry and stop it when the soil becomes moist. The results show a significant increase in moisture with stable pH monitoring. Therefore, the system is effective in maintaining soil moisture and is feasible for automatic watering of tomato plants.

### 3.4 Black Box Testing

#### A. Soil Moisture Sensor Testing with Soil

Table 9. Soil Moisture Sensor Testing with Soil

No	Test Scenario	Expected Result	Result
1	Inserting a soil moisture sensor into dry soil on a tomato plant	The website displays the soil moisture value	Success
2	Inserting a soil moisture sensor into wet soil on a tomato plant	The website displays the soil moisture value	Success

Soil moisture testing on tomato plants was conducted to ensure the system operates according to its function. The soil moisture sensor inserted into wet and dry soil conditions produces different values that can be monitored through the website. The test results show that the sensor can accurately read soil conditions, so the system is declared to function properly according to the design.

## B. Soil pH Sensor Testing with Soil

Table 10. Hasil Pengujian sensor Ph tanah dengan tanah

No	Test Scenario	Expected Result	Result
1	Inserting a soil Ph sensor into the soil on a tomato plant	The website displays the soil Ph value	Success

Testing of the soil pH sensor on tomato plants was conducted to determine the pH value, which is then monitored through the website. The results show that data reading integration runs properly and the system functions according to the design.

## C. Automatic Pump Testing

Table 11. Automatic Pump Testing

No	Test Scenario	Expected Result	Result
1	The pump turns on if the soil moisture sensor is in dry soil conditions	The pump turns on, and the website displays the pump status	Success
2	The pump turns off if the soil moisture sensor is in wet soil	The pump turns off, and the website displays the pump status	Success

Automatic pump testing was conducted to ensure the watering system works according to its function. When the soil moisture sensor detects dry soil, the pump is automatically activated and will stop when the soil becomes wet. The pump status is displayed on the website. The test results show that the system response runs as expected and the pump functions properly.

## CONCLUSION

1. The IoT-based automatic watering system using ESP32 was successfully designed and implemented.
2. The system accurately monitors soil moisture and pH and controls the water pump automatically based on predefined thresholds.
3. The web-based monitoring platform provides real-time data visualization and historical records.

The developed system effectively improves efficiency in tomato plant maintenance and supports smart agriculture implementation.

## REFERENCES

- [1] A. Setiawan dan B. Nugroho, "Implementasi Internet of Things pada Sistem Monitoring Pertanian," *Jurnal Teknologi Informasi*, vol. 8, no. 2, 2020.
- [2] R. Firmansyah dan D. Kurniawan, "Penerapan IoT pada Smart Farming Berbasis

- Sensor,” *Jurnal Informatika*, vol. 9, no. 1, 2021.
- [3] F. R. Perdana, “Analisis Pengaruh pH Tanah terhadap Pertumbuhan Tanaman,” *Jurnal Pertanian Digital*, vol. 3, no. 2, 2024.
- [4] M. Fadhilah, “Rancang Bangun Sistem Penyiraman Otomatis Berbasis IoT,” *Jurnal Sistem Komputer*, vol. 10, no. 1, 2021.
- [5] H. Pratama dan S. Wijaya, “Monitoring Kelembapan dan pH Tanah Berbasis IoT,” *Jurnal Ilmiah Informatika*, vol. 11, no. 2, 2023.
- [6] S. Rahman, “Metode Prototype dalam Pengembangan Sistem Informasi,” *Jurnal Rekayasa Perangkat Lunak*, vol. 7, no. 1, 2020.
- [7] A. Nugraha, “Pemanfaatan ESP32 pada Sistem IoT,” *Jurnal Teknik Elektro*, vol. 5, no. 2, 2021.
- [8] D. Saputra, “Karakteristik Sensor Soil Moisture pada Sistem Monitoring Tanaman,” *Jurnal Elektronika*, vol. 6, no. 1, 2022.
- [9] I. Maulana, “Implementasi Sensor pH Tanah untuk Pertanian Presisi,” *Jurnal Teknologi Pertanian*, vol. 4, no. 2, 2023.
- [10] L. Andriyani, “Pengembangan Dashboard Monitoring Berbasis Web untuk Sistem IoT,” *Jurnal Sistem Informasi*, vol. 12, no. 1, 2022.